

Manual Rupture Versus Transvaginal Ultrasound-guided Aspiration of Allanto-amniotic Fluid in Multiple Pregnancies: A Clinical Approach to Embryo Reduction in Dairy Cattle

Cristina ANDREU-VÁZQUEZ¹), Irina GARCIA-ISPIERTO²) and Fernando LÓPEZ-GATIUS²)

¹Department of Animal Health and Anatomy, Autonomous University of Barcelona, 08193 Bellaterra (Cerdanyola del Vallès), Spain

²Department of Animal Production, University of Lleida, 25198 Lleida, Spain

Abstract. To avoid the problems associated with twinning in dairy cattle, one of the embryos may be eliminated. This study compares the effect on pregnancy maintenance of two embryo reduction techniques, manual rupture (MR) and transvaginal ultrasound-guided aspiration (TUGA) of allanto-amniotic fluid, in Holstein-Friesian cows with multiple pregnancies. In the first experiment, 61 lactating cows bearing unilateral twins (n=27), bilateral twins (n=30) or triplets/quadruplets (n=4) were subjected to MR (n=45) or TUGA using a 17-G needle (n=16) on day 28–34 of gestation. In 21 and 10 cows undergoing MR and TUGA embryo reduction, respectively, pregnancy loss occurred before day 90 (46.7 vs. 62.5%, $P=0.28$). Through binary logistic regression, the type of pregnancy was identified as the only variable significantly affecting pregnancy maintenance ($P=0.03$). Based on the odds ratio, the risk of pregnancy loss was 4.1 times higher for unilateral twins than for bilateral twins (70.4 vs. 36.7%, respectively, $P=0.01$). No effect was detected on pregnancy maintenance of the technique used ($P=0.17$) or of the interaction technique by type of pregnancy ($P=0.22$). In the second experiment, a 22-G needle was used to perform TUGA on 22 lactating cows. The pregnancy loss rates were 44.4% (4/9), 18.2% (2/11) and 50% (1/2) for cows bearing unilateral twins, bilateral twins and triplets, respectively. The total pregnancy loss rate following TUGA using the 22-G needle tended to be lower than that using the 17-G needle (31.8 vs. 62.5%; $P=0.06$). Our results suggest that TUGA using a 22-G needle could be the method of choice to perform embryo reduction in cows carrying multiple pregnancies.

Key words: Dairy cattle, Embryo reduction, Quadruplets, Triplets, Twin pregnancy

(J. Reprod. Dev. 58: 420–424, 2012)

Multiple pregnancies (twins or higher-order pregnancies) are undesirable in dairy herds. Whilst cows carrying triplets and quadruplets are unlikely to maintain their pregnancies to term [1], cows delivering twins are more likely to suffer peripartum diseases and to be culled [2]. Twinning increases not only the risk of pregnancy loss [3, 4] but also the risks of dystocia, stillbirth and calf mortality [5–8]. Over the past 20 years, twinning rates in dairy cattle have increased alongside milk production [2, 5, 9]. Estimates currently run at 9%, with rates of 0.3% to 12% reported among herds [10], and it is foreseeable that this twinning rate will continue to increase.

Transforming a multiple pregnancy into a singleton pregnancy by inducing embryo reduction should in theory avoid the negative effects of multiple pregnancies in dairy cattle. However, the embryo reduction technique itself may carry an additional risk of pregnancy loss. Embryo reduction by manual rupture (MR) of the amniotic vesicle during the late embryonic/early fetal period has been assessed in unilateral [11, 12] and bilateral twin pregnancies [12]. In these studies, pregnancy loss rates of 28.6 to 100% were reported. Transvaginal

ultrasound-guided aspiration (TUGA) is an alternative method to MR for embryo reduction in twin-pregnant mares [13–15], although as far as we know, TUGA has not been used to address the problem of multiple pregnancies in high producing dairy cows. The aim of this study was to compare the effect on pregnancy maintenance of inducing embryo reduction by MR or TUGA in dairy cows with multiple pregnancies.

Materials and Methods

Animal management

This study was performed on a commercial dairy herd comprised of 1128 mature Holstein-Friesian cows in northeastern Spain selected because of its high twinning rate (17.1%) and high pregnancy loss rate for cows carrying twins (32.1%) recorded over the preceding 6-month period [12]. Mean annual milk production for the herd was 10360 kg per cow. The cows were milked three times daily, kept in open stalls and fed complete rations in line with NRC recommendations [16]. All cows were tested free of tuberculosis and brucellosis and artificially inseminated using semen from sires of proven fertility. The mean annual culling rate for the study period was 33%.

The herd was maintained on a weekly reproductive program. Normal uterine involution and the morphology of ovarian structures were checked by palpation per rectum 30–36 days post partum. Any postpartum reproductive disorders diagnosed were treated until

Received: February 23, 2012

Accepted: March 16, 2012

Published online in J-STAGE: April 13, 2012

©2012 by the Society for Reproduction and Development

Correspondence: C Andreu-Vázquez (e-mail: cristina.andreu.vazquez@uab.cat)

resolved or until culling. The voluntary waiting period from calving to first insemination was 60 days. Only cows devoid of detectable reproductive disorders were inseminated.

Pregnancy diagnosis and number and viability of embryos

Pregnancy was diagnosed by transrectal ultrasonography on day 28–34 post insemination using a portable B-mode ultrasound scanner (SonoSite 180 PLUS Vet scanner equipped with a 5–10 MHz transducer; SonoSite, Bothell, WA, USA). Scanning was performed along the dorso/lateral surface of each uterine horn. Twins were recorded on observation of two embryos in different positions within one uterine horn on two scans, two embryos simultaneously present on the screen (unilateral twin pregnancy) or one embryo in each uterine horn (bilateral twin pregnancy). Higher-order pregnancies were recorded when three or more embryos were observed in one or both uterine horns. The viability of the embryos was determined by detecting their heartbeat. Cows carrying one or more dead embryos were excluded from the study.

Embryo reduction by MR or TUGA and pregnancy follow-up examinations

All procedures were approved by the Ethics Committee on Animal Experimentation of the University of Lleida (license numbers CEEA.09-01/11 and CEEA.10-01/11).

Embryo reduction was always conducted on the day of pregnancy diagnosis (day 28–34 of gestation). For the first experiment, 61 lactating cows bearing unilateral twins ($n=27$), bilateral twins ($n=30$) or with higher-order pregnancies ($n=4$) were subjected to embryo reduction. Because MR proved to be relatively successful in a previous study [12], for the first experiment, TUGA was carefully introduced as an alternative embryo reduction method, such that, in chronological order of pregnancy diagnosis, for every 3 cows undergoing MR ($n=45$), TUGA was conducted in a further cow ($n=16$). Thirty minutes prior to embryo reduction, all cows received 1250 mg flunixin meglumine i.m. (Flunex Industrial Veterinaria S.A., Barcelona, Spain) to counteract prostaglandin release due to manipulation of the uterus. For MR, the amniotic vesicle of a twin embryo was pressed with the thumb to cause its rupture [12]. For TUGA, we used a portable B-mode ultrasound scanner (HS-1500 V; Honda Electronics Co., Ltd, Toyohashi, Japan) equipped with a convex 5–10 MHz transducer (HCV-3710MV; Honda Electronics, Toyohashi, Japan) for transvaginal use. A sterile 50-cm-long 17-G needle with an echogenic tip (COVA needle type-A; Misawa Medical Industry, Tokyo, Japan) was used for puncture and aspiration. TUGA was performed on standing animals under epidural anesthesia by infusing 0.04 mg/kg of 2% xylazine (Rompun; Bayer, Barcelona, Spain). The transducer was inserted into the anterior vagina, and the position of the uterus was corrected per rectum until the amniotic vesicle and embryo could be visualized on the ultrasound screen. A puncture guide on the screen was used to draw the correct path for needle placement in the amniotic vesicle. An assistant passed the needle through the needle guide-tube located on the handle of the transducer and pushed it against the fornix and uterine wall until the echogenic tip of the needle could be seen inside the amniotic vesicle. A 20-ml syringe attached to the needle was used to aspirate allanto-amniotic fluid.

For the second experiment, 22 lactating cows bearing unilateral twins ($n=9$), bilateral twins ($n=11$) or triplets ($n=2$) were subjected to TUGA using a modified needle with a 9-cm-long 22-G tip attached to a 40-cm-long 17-G body (Fig. 1). Drug administration and embryo reduction were conducted as described above. Additionally, cows were treated with nonteratogenic antibiotics (750 mg of ceftiofur s.c., Cevaxel; CEVA Salud Animal, Barcelona, Spain) immediately after TUGA and 24 h and 48 h later.

MR and TUGA procedures were always conducted by the same operator. Embryo death was assessed through the disappearance of the heartbeat detected by ultrasonography. For cows carrying triplets/quadruplets, embryo reduction was performed repeatedly to only preserve one embryo. Immediately after embryo reduction, all cows were fitted with a progesterone releasing intravaginal device (PRID, containing 1.55 g of progesterone; CEVA Salud Animal, Barcelona, Spain) for 28 days.

Weekly follow-up examinations to assess the presence and viability of an embryo/fetus were performed by ultrasound until day 56–62 of gestation or until pregnancy loss. Pregnancy was further confirmed by rectal palpation on day 90. Pregnancy loss was recorded when the embryo/fetus was not longer present or when no heartbeat was detected.

Data collection and statistical analysis

The following data were recorded for each animal: embryo reduction method (MR or TUGA); type of pregnancy (bilateral twins, unilateral twins or higher-order pregnancy); gestational stage on the day of embryo reduction; parity; interval from calving to conception; milk production at the time of pregnancy diagnosis; and date of pregnancy loss (if this occurred).

Only pregnancy losses occurring before day 90 of gestation were interpreted as being induced by embryo reduction. For the first experiment, logistic regression procedures were used to evaluate the relative contribution of each variable potentially affecting to the probability of pregnancy loss before day 90. Binary logistic regression was performed according to the method of Hosmer and Lemeshow [17] and considering pregnancy loss before day 90 as the dependent variable and embryo reduction method, parity, type of pregnancy, gestational stage on the day of embryo reduction, days from calving to conception and milk production on pregnancy diagnosis as independent variables. For bilateral twins, unilateral twins and higher-order pregnancies, differences in rates of pregnancy loss for the MR and TUGA embryo reduction techniques were compared by the chi-square or Fisher's exact tests. Differences in rates of pregnancy loss for the TUGA using a 22-G needle and TUGA using a 17-G needle were compared by the chi-square test. All statistics procedures were performed using the SPSS package version 15.0 (SPSS, Chicago, IL, USA) with 0.05 as the level of significance.

Results

In the first experiment, pregnancy loss before day 90 was recorded in 21 cows undergoing embryo reduction by MR and 10 cows undergoing embryo reduction by TUGA (46.7 vs. 62.5%, $P=0.28$). During weeks one to four following embryo reduction, 7, 14, 7 and 2 pregnancy losses occurred respectively, whereas in one cow,

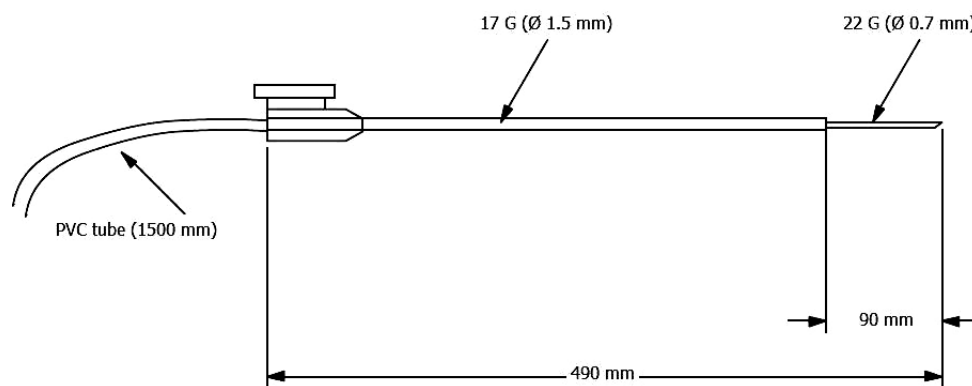

Fig. 1. Design for the modified needle, which has a 9-cm-long 22-G tip attached to a 40-cm-long 17-G body, used for TUGA in the second experiment.

Table 1. Pregnancy losses before day 90 after embryo reduction by manual rupture (MR) or transvaginal ultrasound-guided aspiration (TUGA) of allanto-amniotic fluid using a 17-G needle in cows carrying bilateral or unilateral twins or with higher-order pregnancies

	n	Pregnancy loss before day 90 (%)*	
		Embryo reduction by MR	Embryo reduction by TUGA
Multiple pregnancies	61	21/45 (46.7)	10/16 (62.5)
Bilateral twins	30	6/20 (30.0)	5/10 (50.0)
Unilateral twins	27	14/22 (63.3)	5/5 (100.0)
Higher order	4	1/3 (33.3)	0/1 (0.0)

* No significant differences between the MR and TUGA embryo reduction methods.

pregnancy loss occurred between days 60 and 90 of pregnancy. No pregnancy loss occurred after day 90. Logistic regression analysis indicated no significant effects on pregnancy loss before day 90 of the embryo reduction method used, parity, gestational stage on the day of embryo reduction, days from calving to conception and milk production. The type of pregnancy was the only variable significantly affecting pregnancy loss (likelihood ratio test 7.804; 2 d.f., $P=0.02$, Nagelkerke $r^2=0.16$). Based on the odds ratio, the risk of pregnancy loss was 4.1 times higher for unilateral twins (70.4%) than for bilateral twins (36.7%; 95% confidence interval for the odds ratio: 1.35–12.45, $P=0.01$). Table 1 shows the pregnancy loss rates before day 90 for cows bearing bilateral twins, unilateral twins or with higher-order pregnancies after embryo reduction by MR or TUGA. Pregnancy loss rates associated with the TUGA and MR methods failed to differ for all pregnancy types.

For the second experiment pregnancy loss before day 90 was recorded in 7 of the 22 cows. The pregnancy loss rate following TUGA using a 22-G needle tended to be lower than that following TUGA using the 17-G needle (31.8 vs. 62.5%; $P=0.06$). Table 2 shows the pregnancy loss rates before day 90 for cows bearing bilateral twins, unilateral twins or with higher-order pregnancies after TUGA performed using the 22-G needle. All 7 pregnancy losses occurred during the three weeks following embryo reduction.

The culling rate for cows suffering pregnancy loss after embryo reduction was 25.8%. All animals became pregnant again, with an interval mean of 51.8 ± 47.0 days from pregnancy loss to conception.

Table 2. Pregnancy losses before day 90 after embryo reduction by transvaginal ultrasound-guided aspiration (TUGA) of allanto-amniotic fluid using a 22-G needle in cows carrying bilateral or unilateral twins or with higher-order pregnancies

	n	Pregnancy loss before day 90 (%)
Multiple pregnancies	22	7/22 (31.8)
Bilateral twins	11	2/11 (18.2)
Unilateral twins	9	4/9 (44.4)
Higher order	2	1/2 (50.0)

Discussion

Embryo reduction to prevent the negative effects of multiple pregnancies in dairy cattle is not a risk-free procedure. Herein, embryo reduction was conducted in a total of 83 Holstein-Friesian lactating cows. The overall pregnancy loss rate for the cows undergoing embryo reduction in this study was 45.8%, whereas a 32.1% pregnancy loss rate was registered for non-reduced twin-pregnant cows of the same commercial dairy herd in the previous 6-month period [12]. Despite this, transforming a multiple pregnancy into a singleton pregnancy by inducing embryo reduction may prevent likely postpartum problems and infertility following twinning. Thus, regardless of the pregnancy loss risk, further aspects related to herd productivity and profitability need to be considered when assessing

the cost-effectiveness of embryo reduction.

Among the embryo reduction methods assessed in this study, the highest rate of pregnancy maintenance following embryo reduction was achieved when using the 22-G needle for TUGA, with an overall pregnancy loss rate of 31.8%. The figure reached 46.7% when embryo reduction was conducted by MR and was 62.5% when TUGA was performed using a conventional 17-G needle. In a previous study, we reported a similar rate for the MR method [12]. On the other hand, we have no figure to compare our rate of pregnancy loss for the TUGA embryo reduction technique, since, as far as we know, there are no prior data on its use in dairy cattle. In human obstetrics, TUGA and modified versions of this technique have been widely used to avoid the risks of multiple pregnancies, and it is considered a safe technique with a miscarriage rate of less than 12% when performed before the 8th week of gestation [18]. TUGA has also been used for embryo reduction in equine medicine with success rates ranging from 9 to 75%, depending on the gestation time when it is performed and the location of the co-twin embryonic vesicles [13–15]. However, the MR method of embryo reduction is the procedure of choice in twin-pregnant mares, its success rate being greater than 90% when embryo vesicles are still movable through the uterine lumen (prior to day 16 post insemination), and TUGA has been restricted to situations in which MR is no longer accessible [14, 19].

Regardless of the embryo reduction method used, pregnancy maintenance rates were improved when embryo reduction was conducted in bilateral rather than unilateral twin pregnancies. This is in agreement with the findings of previous studies in which unilateral twin pregnancies were found to be more likely to fail than bilateral twins if the pregnancy was not reduced [20], following spontaneous embryo reduction [20] or following induced embryo reduction [12]. Close contact between unilateral twin conceptuses and interchorionic vascular anastomoses [1, 21] are probably related to this high risk of pregnancy loss. However, when assessing which embryo reduction method would be more suitable for each pregnancy type, it was determined through logistic regression that neither MR nor TUGA using the 17-G needle (first experiment) proved to be safer than the other technique.

The success of TUGA using a 22-G needle over MR or TUGA using a conventional 17-G needle can be related to a lower degree of inflammation induced by the procedure that might compromise pregnancy maintenance following embryo reduction. Whilst in embryo reduction through MR, pressure is applied over a larger uterine area, TUGA disrupts the uterine wall at the site of puncture. Similarly, the use of a 21–22-G needle has been described to be less traumatic for the gravid uterus [22–24] than a 17–18-G needle [24, 25] when collecting fetal fluids in the cow. However, not only the use of a thinner needle but also the antibiotic prophylaxis could be responsible for the differences between the pregnancy loss rates following TUGA recorded in the first and second experiments. Introduction of bacteria inside of the gravid uterus through the site of puncture is likely to occur following TUGA, and administration of antibiotics to the cows enrolled in the second experiment may have led to better rates of pregnancy maintenance. Iatrogenic uterine inflammation and chorioamnionitis following TUGA have been reported in women [26] and mares [27], and antibiotic prophylaxis is always given in both women and mares to counteract uterine infection after any embryo

reduction procedure that involves puncturing the uterine wall. In cattle, pregnancy loss after amniocentesis or allantocentesis has been associated with bacterial infection [22], and systemic antibiotics are also indicated [23, 24].

In both experiments, most pregnancy losses occurred during the first three weeks following embryo reduction, and only a few cows (3 of the 38 pregnancy losses, 7.9%) lost their pregnancies later, in agreement with data reported for the mare [14] and cows suffering spontaneous embryo reduction [20]. In most cases, pregnancy loss was preceded by signs of embryo death such as weak heart activity, detached membranes or amnion turbidity detected in the weekly ultrasound follow-up exams. Additionally, in some animals, detritus of the reduced embryo was visible for as long as two weeks after the reduction procedure. It has been suggested that necrotic material remaining in the uterus induces uterine prostaglandin release, which has a luteolytic effect promoting pregnancy loss after multifetal pregnancy reduction in women [28]. To counteract this, progesterone supplementation is recommended and has been shown to improve pregnancy maintenance after embryo reduction in both mares [14] and cows [11, 12].

Finally and from a clinical perspective, there is a need for discerning an accurate hormone, antibiotic and anti-inflammatory therapy to safely achieve embryo reduction in dairy cattle. Besides this, certain modifications to the TUGA embryo reduction technique could help improve results. Intracardiac/intrathoracic embryo puncture with or without injection of an embryotoxic agent has been attempted in human [18, 26, 29] and equine medical practice [30] as an alternative to fetal fluid aspiration. Evacuation of the amniotic fluid has been suggested to damage the remaining embryo when its placental membranes are inadvertently aspirated [14]. This would be even more critical in cattle in which most unilateral and some bilateral twin embryos are in very close contact with each other.

In conclusion, both the MR and TUGA methods of embryo reduction could be conducted in dairy cattle in order to prevent the negative effects of twin calvings. Our results suggest that TUGA using a 22-G needle could be the method of choice for performance of embryo reduction in cows carrying multiple pregnancies. Further studies are needed to establish an effective hormonal, antibiotic and anti-inflammatory therapy in order to prevent pregnancy loss following embryo reduction.

Acknowledgments

The authors thank Ana Burton for assistance with the English writing revision, the owners and staff of the farm Sant Jaume de Palau and Misawa Medical Industry Co., Ltd. for manufacturing the 22-G needle. Andreu-Vázquez was supported by an FPU grant from the Ministerio de Educación y Ciencia (AP-2007-01598).

References

1. Echterkamp SE. Fetal development in cattle with multiple ovulations. *J Anim Sci* 1992; **70**: 2309–2321. [Medline]
2. Bicalho RC, Cheong SH, Galvao KN, Warnick LD, Guard CL. Effect of twin birth calvings on milk production, reproductive performance, and survival of lactating cows. *J Am Vet Med Assoc* 2007; **231**: 1390–1397. [Medline] [CrossRef]
3. Lopez-Gatius F, Szenci O, Bech-Sabat G, Garcia-Ispuerto I, Serrano B, Santolaria P,

- Yaniz J.** Factors of non-infectious nature affecting late embryonic and early foetal loss in high producing dairy herds in north-eastern Spain. *Magyar Allatorvosok Lapja* 2009; **131**: 515–531.
4. **López-Gatius F, García-Ispuerto I.** Ultrasound and endocrine findings that help to assess the risk of late embryo/early foetal loss by non-infectious cause in dairy cattle. *Reprod Domest Anim* 2010; **45**(Suppl 3): 15–24. [[CrossRef](#)]
 5. **Nielen M, Schukken YH, Scholl DT, Wilbrink HJ, Brand A.** Twinning in dairy cattle: A study of risk factors and effects. *Theriogenology* 1989; **32**: 845–862. [[Medline](#)] [[Cross-Ref](#)]
 6. **Gregory KE, Echternkamp SE, Dickerson GE, Cundiff LV, Koch RM, Van Vleck LD.** Twinning in cattle: III. Effects of twinning on dystocia, reproductive traits, calf survival, calf growth and cow productivity. *J Anim Sci* 1990; **68**: 3133–3144. [[Medline](#)]
 7. **Eddy RG, Davies O, David C.** An economic assessment of twin births in British dairy herds. *Vet Rec* 1991; **129**: 526–529. [[Medline](#)]
 8. **Beerepoot GM, Dykhuizen AA, Nielen M, Schukken YH.** The economics of naturally occurring twinning in dairy cattle. *J Dairy Sci* 1992; **75**: 1044–1051. [[Medline](#)] [[Cross-Ref](#)]
 9. **Kinsel ML, Marsh WE, Ruegg PL, Etherington WG.** Risk factors for twinning in dairy cows. *J Dairy Sci* 1998; **81**: 989–993. [[Medline](#)] [[CrossRef](#)]
 10. **Silva del Río N, Stewart S, Rapnicki P, Chang YM, Fricke PM.** An observational analysis of twin births, calf sex ratio, and calf mortality in Holstein dairy cattle. *J Dairy Sci* 2007; **90**: 1255–1264. [[Medline](#)] [[CrossRef](#)]
 11. **López-Gatius F.** The effect on pregnancy rate of progesterone administration after manual reduction of twin embryos in dairy cattle. *J Vet Med A Physiol Pathol Clin Med* 2005; **52**: 199–201. [[Medline](#)] [[CrossRef](#)]
 12. **Andreu-Vázquez C, García-Ispuerto I, Lopez-Bejar M, de Sousa NM, Beckers JF, Lopez-Gatius F.** Clinical implications of induced twin reduction in dairy cattle. *Theriogenology* 2011; **76**: 512–521. [[Medline](#)] [[CrossRef](#)]
 13. **Bracher V, Parlevliet JM, Pieterse MC, Vos PL, Wiemer P, Taverne MA, Colenbrander B.** Transvaginal ultrasound-guided twin reduction in the mare. *Vet Rec* 1993; **133**: 478–479. [[Medline](#)] [[CrossRef](#)]
 14. **Macpherson ML, Reimer JM.** Twin reduction in the mare: current options. *Anim Reprod Sci* 2000; **60-61**: 233–244. [[Medline](#)] [[CrossRef](#)]
 15. **Mari G, Iacono E, Merlo B, Castagnetti C.** Reduction of twin pregnancy in the mare by transvaginal ultrasound-guided aspiration. *Reprod Domest Anim* 2004; **39**: 434–437. [[Medline](#)] [[CrossRef](#)]
 16. **National Research Council** Nutrient requirements of dairy cattle. Washington DC: National Academic Science; 2001.
 17. **Hosmer D, Lemeshow S.** Applied Logistic Regression. New York: Wiley; 1989.
 18. **Lee JR, Ku SY, Jee BC, Suh CS, Kim KC, Kim SH.** Pregnancy outcomes of different methods for multifetal pregnancy reduction: a comparative study. *J Korean Med Sci* 2008; **23**: 111–116. [[Medline](#)] [[CrossRef](#)]
 19. **Ragon AC.** Management of Twin Pregnancy. In: Youngquist RS (ed.), Current Therapy in Large Animal Theriogenology. St Louis: WB Saunders; 2007: 114–117.
 20. **López-Gatius F, Hunter RH.** Spontaneous reduction of advanced twin embryos: its occurrence and clinical relevance in dairy cattle. *Theriogenology* 2005; **63**: 118–125. [[Medline](#)] [[CrossRef](#)]
 21. **Williams G, Gordon I, Edwards J.** Observations on the frequency of fused foetal circulations in twin-bearing cattle. *Brit Vet J* 1963; **119**: 467–472.
 22. **Kamimura S, Nishiyama N, Ookutsu S, Goto K, Hamana K.** Determination of bovine fetal sex by PCR using fetal fluid aspirated by transvaginal ultrasound-guided amniocentesis. *Theriogenology* 1997; **47**: 1563–1569. [[Medline](#)] [[CrossRef](#)]
 23. **García A, Salaheddine M.** Bovine ultrasound-guided transvaginal amniocentesis. *Theriogenology* 1997; **47**: 1003–1008. [[Medline](#)] [[CrossRef](#)]
 24. **Makondo K, Amiridis GS, Jeffcoate IA, O'Shaughnessy PJ, Boyd JS, Paterson C, Robertson L.** Use of the polymerase chain reaction to sex the bovine fetus using cells recovered by ultrasound-guided fetal fluid aspiration. *Anim Reprod Sci* 1997; **49**: 125–133. [[Medline](#)] [[CrossRef](#)]
 25. **Bellow MS, Feeleus WN, Ohlrichs CL, Johnson DL, Looney CR.** Application of transvaginal ultrasound for performing amniocentesis in cattle. *Theriogenology* 1996; **45**: 225. [[CrossRef](#)]
 26. **Ibérico G, Navarro J, Blasco L, Simon C, Pellicer A, Remohi J.** Embryo reduction of multifetal pregnancies following assisted reproduction treatment: a modification of the transvaginal ultrasound-guided technique. *Hum Reprod* 2000; **15**: 2228–2233. [[Medline](#)] [[CrossRef](#)]
 27. **Squires E, Tarr S.** Use of transvaginal ultrasound-guide puncture for elimination of equine pregnancies during days 50 to 65. *J Equine Vet Sci* 1994; **14**: 203–206. [[CrossRef](#)]
 28. **Sebire NJ, Sherod C, Abbas A, Snijders RJ, Nicolaidis KH.** Preterm delivery and growth restriction in multifetal pregnancies reduced to twins. *Hum Reprod* 1997; **12**: 173–175. [[Medline](#)] [[CrossRef](#)]
 29. **Mansour RT, Aboulghar MA, Serour GI, Sattar MA, Kamal A, Amin YM.** Multifetal pregnancy reduction: modification of the technique and analysis of the outcome. *Fertil Steril* 1999; **71**: 380–384. [[Medline](#)] [[CrossRef](#)]
 30. **Raggio I, Lefebvre RC, Poitras P, Vaillancourt D, Goff AK.** Twin pregnancy experimental model for transvaginal ultrasound-guided twin reduction in mares. *Can Vet J* 2008; **49**: 1093–1098. [[Medline](#)]